

REV.	ECN NO.	LOCATIONS	DESCRIPTION	DATE	DESIGN
A0			New Release	13/03'17	Larry

CUSTOMER DRAWING

RoHS Compliant

ORDERING INFORMATION

MCCFT-R2Z2 (XX T)

① ② ③

- ① **PRODUCT SERIES:**
 USB C TYPE connector –
 Receptacle (Female) side.
- ② **ITEM NO.:**
 Right Angle– Dual Row 24 pin
 Standard on board type.

- ③ **GOLD PLATING :**
 01: G/F
 03: 3u”
 05: 5u”
 15: 15u”
 30: 30u”

3D VIEW

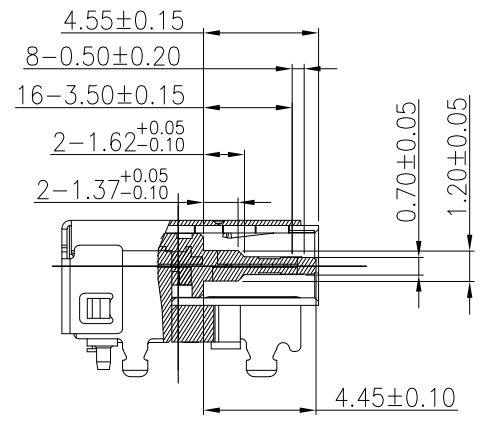
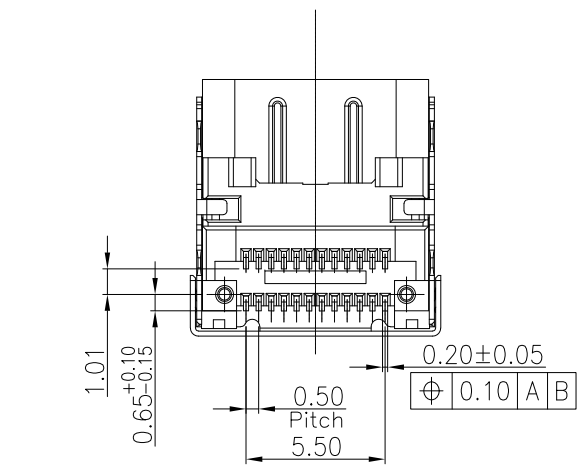
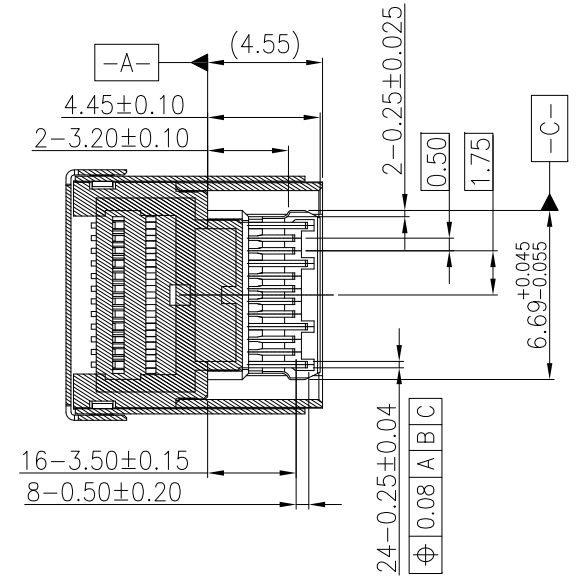
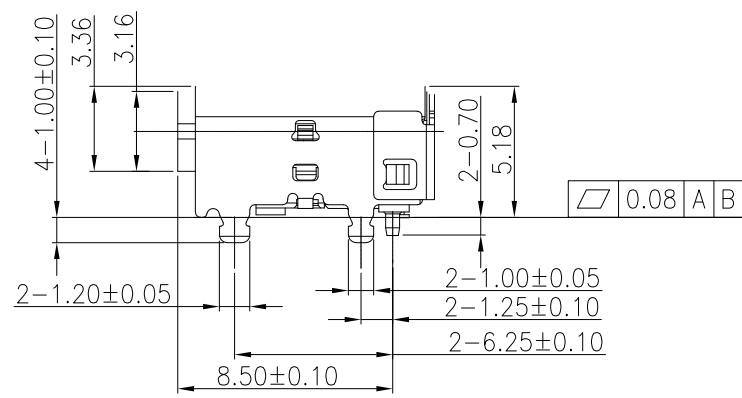
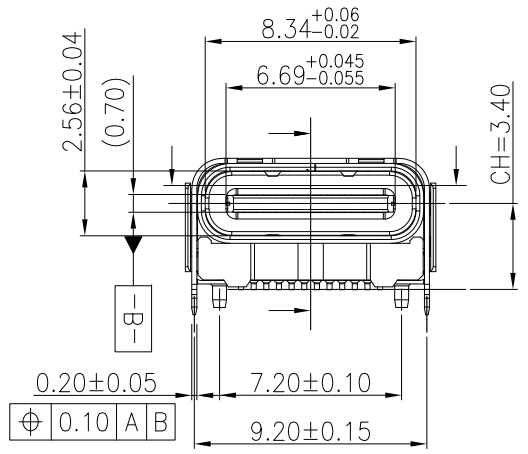
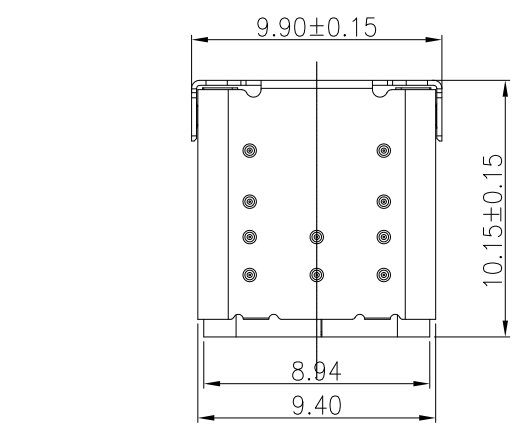
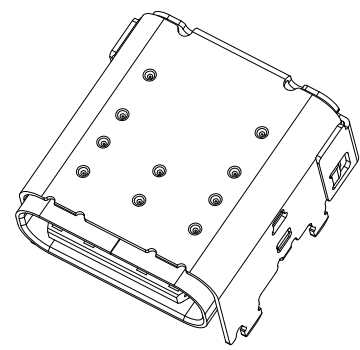

NOTES:

1. MATERIAL:
 (1) HOUSING: HIGH TEMP plastic, UL94 V-0.
 (2) CONTACT: COPPER ALLOY.
 (3) MID PLATE: STAINLESS STEEL.
 (4) SHELL: STAINLESS STEEL.
2. PLATED:
 (1) CONTACT: GOLD ON CONTACT AREA OVER NICKEL PLEATED OVERALL.
 (2) SHELL: NICKEL PLATED ON SOLDER AREA.
 (3) MID PLATE: CLEAR ONLY
3. MECHANICAL PERFORMANCE,
 (1) INSERTION FORCE: 5~20N.
 (2) REMOVAL FORCE: 8~20N.
 (3) DURABILITY: 10,000 CYCLES.
4. ELECTRICAL PERFORMANCE,
 (1) CURRENT RATING: 5.0A
 (2) VOLTAGE RATING: 20V
5. ENVIRONMENTAL PERFORMANCE:
 (1) OPERATING TEMPERATURE: -40°C~+85°C.

DIM	TOL
X.X	±0.30
X.XX	±0.20
X.XXX	±0.10

SUNFUN		SUNFUN TECHNOLOGY LTD			
DRAW NO.	MCCFT-R2Z2(A0)	DATE	13/03'17	MATERIAL:	SEE NOTES
DESIGN:	Larry	DATE	13/03'17	FINISH:	SEE NOTES
CHECK:	Larry	FILE:	MCCFT-R2Z2(A0)	DRAW NAME: USB C Type CONN - FEMALE Right Angle- Dual Row 24 pin Standard on board type.	
REVIEW:	Johnson	P/N:	MCCFT-R2Z2(XXT)	MODEL: USB C TYPE CONN	
APPROVED:	Johnson	REV. A0	SCALE	UNIT:	mm
				SHEET:	1/2

REV.	ECN NO.	LOCATIONS	DESCRIPTION	DATE	DESIGN
A0			New Release	13/03'17	Larry

CUSTOMER DRAWING

RoHS Compliant

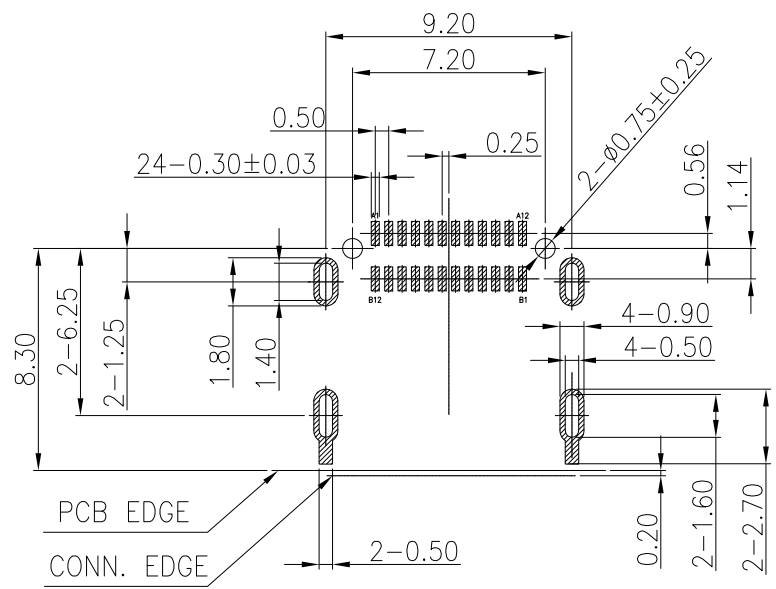

RECOMMENDED P.C.B LAYOUT (TOP VIEW)
 PCB THICKNESS: 1.00MM
 DEFAULT TOLERANCE ±0.05

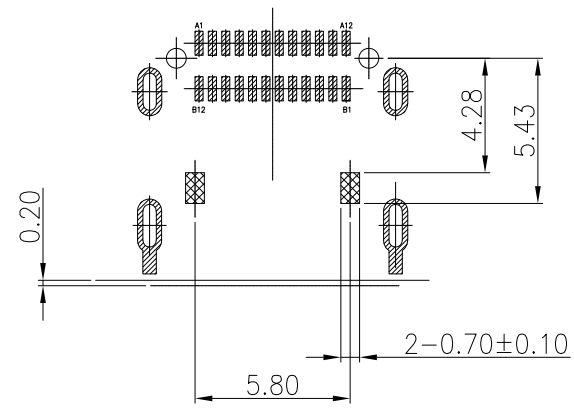

RECOMMENDED CONTACTOR EDGE
 COMPONENT SIDE: TOP VIEW
 ▨ STAND OFF AREA
 ▩ PAD AREA

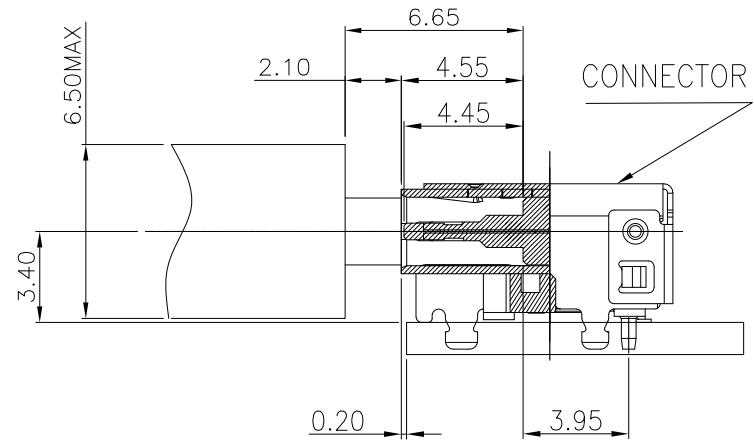

RECOMMENDED METHOD OF MATE
 SCALE: 1:1

PIN ASSIGNMENTS:

A1	A2	A3	A4	A5	A6	A7	A8	A9	A10	A11	A12
GND	TX1+	TX1-	Vbus	CC1	D+	D-	SBU1	Vbus	RX2-	RX2+	GND
B12	B11	B10	B9	B8	B7	B6	B5	B4	B3	B2	B1
GND	RX1+	RX1-	Vbus	SBU2	D-	D+	CC2	Vbus	TX2-	TX2+	GND

DIM	TOL
X.X	±0.30
X.XX	±0.20
X.XXX	±0.10

SUNFUN			SUNFUN TECHNOLOGY LTD				
DRAW NO:	MCCFT-R2Z2(A0)	DATE:	13/03'17	MATERIAL:	SEE NOTES	DRAW NAME:	USB C Type CONN - FEMALE
DESIGN:	Larry	FINISH:	SEE NOTES	FILE:	MCCFT-R2Z2(A0)	MODEL:	USB C TYPE CONN
CHECK:	Larry	P/N:	MCCFT-R2Z2(XXT)	REVIEW:	Johnson	UNIT:	mm
APPROVED:	Johnson	SCALE:		SHEET:	2/2		